

AHP-1152

15" XGA Touch Panel Computer With Intel® Atom™ D510 1.66 GHz Processor

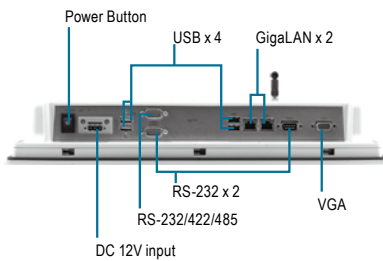
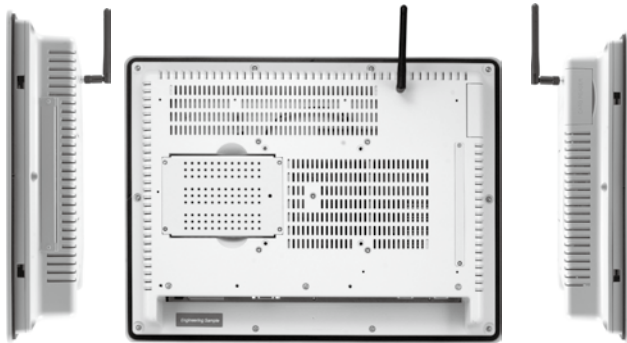

Features

- Onboard Intel® Atom™ D510 1.66 GHz
- 15" 250 Nits XGA CCFL Backlight
15" 800 Nits XGA LED Backlight
- Fanless Operation
- Slim Design: 65mm
- RF ID/ WiFi (Optional)



Specifications

System	
Processor	Intel® Atom™ D510, 1.66 GHz
System Memory	DDR2 SODIMM, Up to 2 GB
LCD/CRT Controller	Integrated in Processor, shared memory up to 224MB
Ethernet	10/100/1000Base-TX, RJ-45 x 2
I/O Port	USB2.0 x 4, RS-232 x 2, RS-232/422/485 x 1, LAN x 2, VGA x 1
Storage Disk Drive	2.5" SATA Hard Disk Driver /CompactFlash™ Slot (Internal)
Expansion Slot	Mini card x 2
OS support	Windows® CE 6.0, Windows® XP Embedded, Windows® XP, Windows® 7, Windows® Embedded Standard 7, Linux Fedora
Mechanical	
Construction	IP-65 certified Plastic front panel Plastic Gray panel
Color	PMS 5425C +Gray
Mounting	VESA 75/100
Dimension	16"(W) x 12.2"(H) x 2.6"(D) (407mm x 310.5mm x 65mm)
Carton Dimension	20.67"(W) x 18.31"(H) x 9.1"(D) (525mm x 465mm x 230mm)
Gross Weight	11.9 lb (5.4 kg)
Net Weight	9.7 lb (4.4 kg)
Environmental	
Operating Temperature	32°F ~ 131°F (0°C ~ 55°C) (Ambient with airflow)
Storage Temperature	-4°F ~ 140°F (-20°C ~ 60°C)
Storage Humidity	5%~90% @ 40°C; non-condensing
Vibration	3 g rms/ 5~ 500Hz/ operation - With HDD
Shock	20 G peak acceleration (11 msec. duration)
EMC	CE /FCC class A
Power Supply	
DC input	DC 12V
LCD	
Display type	15" TFT-LCD
Max Resolution	1024 x 768
Max. Colors	262K colors
Luminance	HTT: 250 cd/m ² / STT: 800 cd/m ²
Viewing Angle	HTT: 170°(H), 160°(V)/ STT: 160°(H), 140°(V)
Back Light	HTT: CCFL/ STT: LED
Back Light MTBF (hours)	HTT: 30,000/ STT: 60,000
Touchscreen	
Type	5-wire, Analog Resistive
Resolution	2048x2048
Light Transmission	>80%
Life time	35 Million activations

AHP-1152

Dimension

Unit: mm

Cutout Size: 394mm x 297,5mm

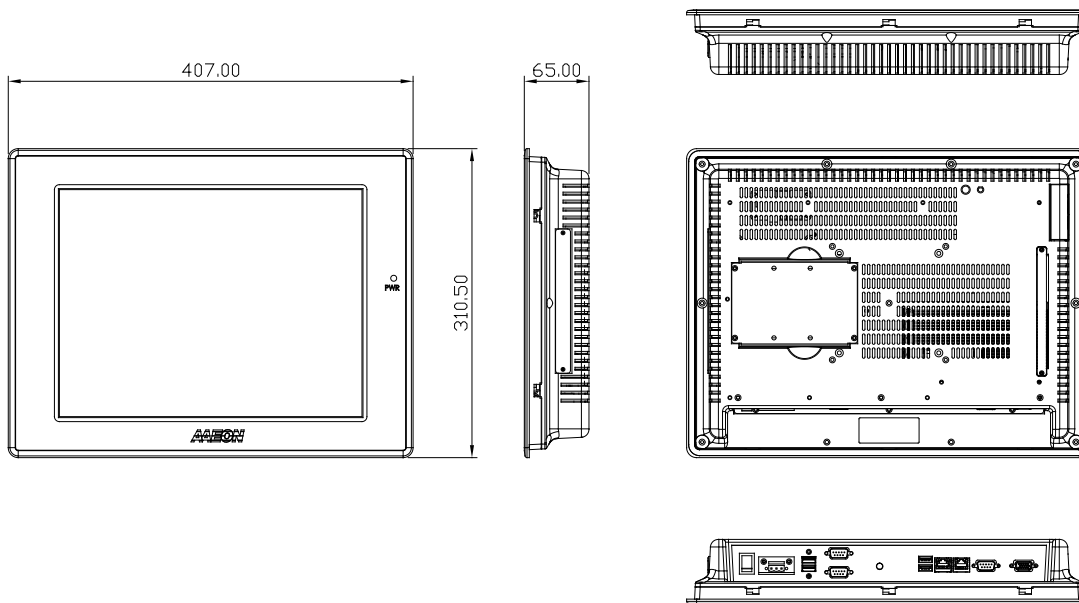

Ordering Information

- **TF-AHP-1152HTT-A1-1000**
HMI Panel PC, Intel® Atom™ D510 1.66 GHz, 15" TFT 250 nits, Fanless, DC 12V, R-TS, 1 G RAM
- **TF-AHP-1152STT-A1-1000**
HMI Panel PC, Intel® Atom™ D510 1.66 GHz, 15" TFT 800 nits, Fanless, DC 12V, R-TS, 1 G RAM

Optional Accessories

- **ARM-DR075-0**
DIN Rail Kit with VESA 75mm Standards
- **ARM-WK075-0**
Wallmount Kit for VESA 75/100mm Standard Screw Holes
- **STAND-8150B0**
Desktop Stand with VESA 100mm Standard
- **1702031830**
Power Cord (US Type)
- **1702031831**
Power Cord (European Type)
- **1757908401**
12V 84W Power Adapter
- **9761115200**
WiFi Kit, 802.11b/g and Bluetooth® V2.0 + EDR
- **9761115201**
RF ID Kit